



◆ Application

- Measure the distance, angle, position acceleration , automatic control , robot, X-Y labor ,printing, molding machine, packing machine, machine tool and etc.

◆ Features

- Miniature size, easy assembling
- 2 quadrature output channel (A&B) + index signal
- Resolution up to 3600 pulses

◆ Ordering Information

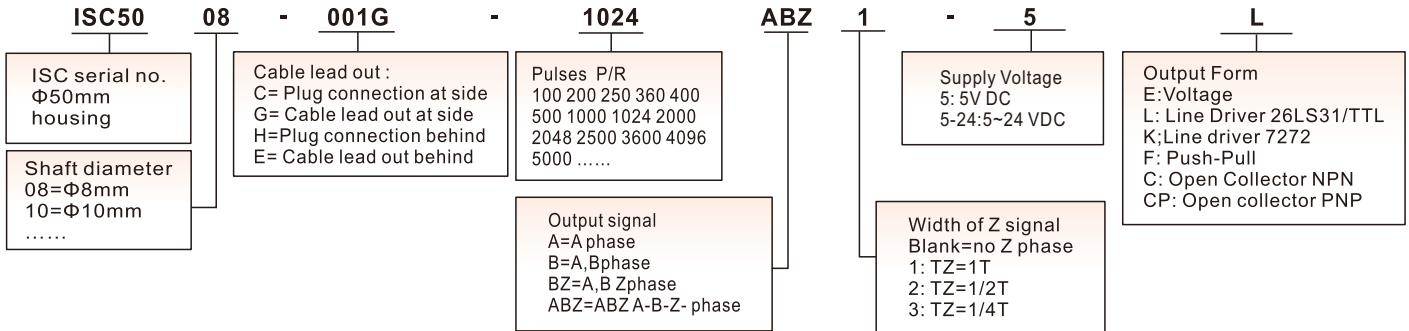

◆ Note:

1. Please contact sales representative to confirm the correctness and availability of the part number

◆ Technical Specifications

Electrical Specification				
Output circuit	Open collector	Voltage output	Push pull output	Line driver output
Power Vcc	5~30	5~30	5±0.25 5~30	5±0.25 5~30
Current	≤80mA	≤80mA	≤80mA	≤150mA
Load current	40mA	40mA	40mA	60mA
High-level output	Min Vcc*70%	Min Vcc-2.5V	Min Vcc-1.5V	Min 3.4V
Low-level output	Max 0.4V	Max 0.4V	Max 0.8V	Max 0.4V
Rise Time Tr	Max 1us	Max 1us	Max 1us	Max 200ns
Fall Time Tr	Max 1us	Max 1us	Max 1us	Max 200ns
Max Responding Frequency	300kHz	300kHz	300kHz	300kHz
Mechanical Specification				
Max speed(r/min)	Starting Torque	Max. Shaft Loading	Shocking	Vibration
6000	<0.01Nm	Radial:60N, Axial:30N	50G/11ms	10G 10-2000Hz
Rotor Inertia	Working Temperature	Storage Temperature	Protection Grade	Weight
4*10 <sup>-8</sup> Kgm <sup>2</sup>	-30~85°C	-35~95°C	IP51	250g

◆ Connection Table

Signal	A	B	Z	Ā	B̄	Z̄	Vcc	GND
Color	Green	White	Yellow	Brown	Grey	Orange	Red	Black

◆ Dimensions(mm)

