



◆ Application

- Measure the length or speed of target by wheel type , automatic control , robot, X-Y labor ,printing, packing machine and etc.

◆ Features

- High reliability , long life , strong anti-interference ability
- 2 quadrature output channel (A&B) + index signal

◆ Ordering Information

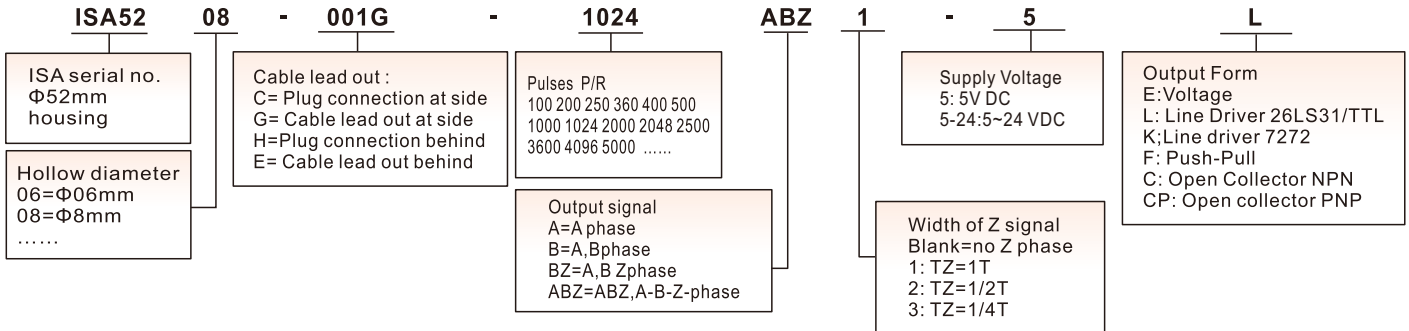

◆ Note:

1. Please contact sales representative to confirm the correctness and availability of the part number

◆ Technical Specifications

Electrical Specification				
Output circuit	Open collector	Voltage output	Push pull output	Line driver output
Power Vcc	5~30	5~30	5±0.25 5~30	5±0.25 5~30
Current	≤80mA	≤80mA	≤80mA	≤150mA
Load current	40mA	40mA	40mA	60mA
High-level output	Min Vcc*70%	Min Vcc-2.5V	Min Vcc-1.5V	Min 3.4V
Low-level output	Max 0.4V	Max 0.4V	Max 0.8V	Max 0.4V
Rise Time Tr	Max 1us	Max 1us	Max 1us	Max 200ns
Fall Time Tr	Max 1us	Max 1us	Max 1us	Max 200ns
Max Responding Frequency	300kHz	300kHz	300kHz	300kHz
Mechanical Specification				
Max speed(r/min)	Starting Torque	Max. Shaft Loading	Shocking	Vibration
6000	<0.05Nm	Radial:25N, Axial:15N	50G/11ms	10G 10-2000Hz
Rotor Inertia	Working Temperature	Storage Temperature	Protection Grade	Weight
4*10 <sup>-8</sup> Kgm <sup>2</sup>	-30~85°C	-35~95°C	IP51	250g

◆ Connection Table(17pin plug)

Signal	A	B	Z	Ā	B̄	Z̄	Vcc	GND
Color	Green	White	Yellow	Brown	Grey	Orange	Red	Black

◆ Dimensions(mm)

