



◆ Application

- Used in area of automatic control, measurements, elevator, printing and packing.

◆ Features

- High reliability, long life, strong anti-interference ability and wide range of temperature adaption.
- Keyway fixation, easy to install and inner diameter changeable.

◆ Ordering Information

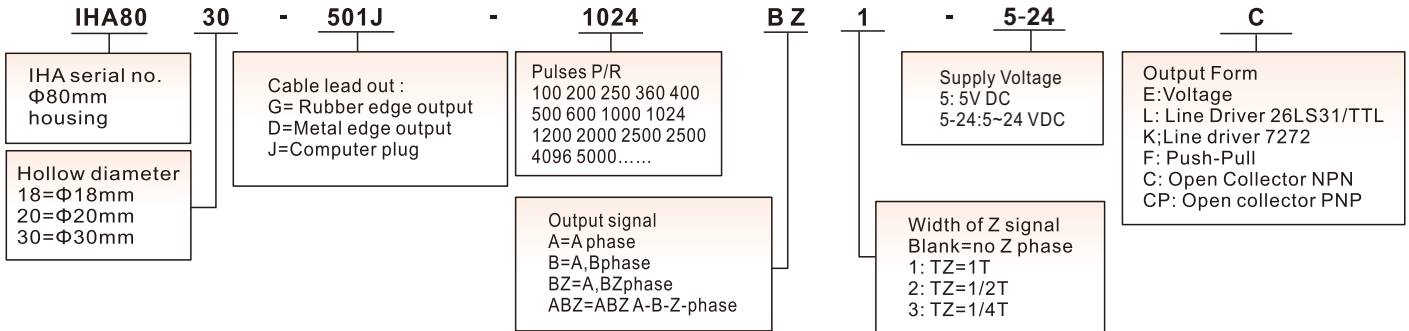

◆ Note:

1. Please contact sales representative to confirm the correctness and availability of the part number

◆ Technical Specifications

Electrical Specification				
Output circuit	Open collector	Voltage output	Push pull output	Line driver output
Power Vcc	5~30	5~30	5±0.25 5~30	5±0.25 5~30
Current	≤80mA	≤80mA	≤80mA	≤150mA
Load current	40mA	40mA	40mA	60mA
High-level output	Min Vcc*70%	Min Vcc-2.5V	Min Vcc-1.5V	Min 3.4V
Low-level output	Max 0.4V	Max 0.4V	Max 0.8V	Max 0.4V
Rise Time Tr	Max 1us	Max 1us	Max 1us	Max 200ns
Fall Time Tr	Max 1us	Max 1us	Max 1us	Max 200ns
Max Responding Frequency	300kHz	300kHz	300kHz	300kHz
Mechanical Specification				
Max speed(r/min)	Starting Torque	Max. Shaft Loading	Shocking	Vibration
6000	<1Nm	Radial:20N, Axial:10N	50G/11-ms	10G 10-2000Hz
Rotor Inertia	Working Temperature	Storage Temperature	Protection Grade	Weight
4*10 <sup>-8</sup> Kgm <sup>2</sup>	-30~85°C	-35~95°C	IP50	500g

◆ Connection Table

Signal	A	B	Z	Ā	B̄	Z̄	Vcc	GND	Shielded
Color	Green	White	Yellow	Brown	Gray	Orange	Red	Black	Copper Web
DB15 plug	4	2	9	-	-	-	7	5	8
DB15 plug	5	3	2	7	6	8	1	4	9

◆ Dimensions(mm)

